



**Technology of the Future
Protection for Today**

The state-of-the-art multi-spectral infrared technology of ESP Safety's Model IPES-IR3 Flame Detector affords the highest sensitivity in detecting flames from combustible vapors gases within a wide field of view. It is preferred where UV in other detectors may be a problem with false signal triggers.

IPES-IR3's advanced detection technology ensures rapid flame recognition and alarm signaling. In addition, IPES-IR3's selective, multi-spectral technology virtually eliminates false alarms. It ignores false triggers from sources such as direct or indirect sunlight, arc welder flash, resistive heaters, fluorescent, halogen, and incandescent light.

IPES-IR3 sends an alarm only when data from three different IR wavelengths agree that a flame or fire is present in the field of view. Upon confirmation of flame or fire, the IPES-IR3 transfers alarm signals to receiving control devices located in control and operations rooms and to fire alarms and burglar/fire alarm systems. While operating, the IPES-IR3 transmits detector-status information via:

- 4-20 current loop w/ HART
- A standard RS-485 communication channel under protocol Modbus RTU
- Relay outputs

The IPES-IR3 Flame Detector is constructed with an explosion-proof housing for use in hazardous (classified) locations. It meets the certifications and requirements of Class I, Division 1, Group B, C & D, T4.

SIL3 RATED



IPES IR3 FLAME DETECTOR

Applications

- Drilling and production platforms
- Shipping tankers, freighters, and other vessels
- Fuel loading facilities
- Refineries, bulk terminals, and tank farms
- LNG/LPG processing and storage facilities
- Compressor stations and pipeline facilities
- Petrochemical, paint, and fertilizer plants
- Power plants and gas turbine facilities
- Transportation facilities (airports and subways)
- Oil and gas fired boilers / furnaces
- Aircraft hangars

Features and Benefits

- Multi-spectral IR detection provides the highest level of flame and fire sensitivity.
- Multi-spectral IR detection provides optimal rejection of false alarms.
- Power-on self-test and frequent sensor self-test ensure system integrity and correct operation.
- Heated optics, secondary heater function helps to prevent condensation problems.
- Explosion-proof package allows for hazardous environment operation.
- Tri-color status LED on the device is easily viewable for a visual report of the device's operating status.
- Continuous monitoring of the optical path for obstruction or reduced transmission affords maximum reliability.
- Power consumption of <3W means low power costs, protection against surges.
- Digital, analog and relay outputs provide reliable status information across a range of communication formats.
- Industry standard for remote alarm and fault indication ensure reliability and consistency.
- Extended detection range provides a greater area of protection.
- 5-year warranty – long, reliable product life; low cost to operate over time.

CONTACT

www.espsafetyinc.com
info@espsafetyinc.com

CALIFORNIA

555 N. First Street | San Jose, CA 95112
Ph: +1-408-886-9746 | Fx: +1-408-886-9757

TEXAS

4001 W. Sam Houston Parkway N. Ste #150 | Houston, TX 77043
Ph: +1-713-999-1050 | Fx: +1-713-999-1060

Certifications



APPROVED
Class I, Division 1
Groups B, C & D
T4 Ta = -40°F to +167°F
(-40°C to +75°C)
IP66



Ex d IIC T4
-40°F to +185°F
(-40°C to +85°C)
CE Mark for EMC (TUV)
CE Mark for IECEx
IP66



Class I, Division 1
Groups B, C & D
T4 Ta = -40°F to +167°F
(-40°C to +75°C)
IP66



Ex d IIC T4
-40°F to +185°F
(-40°C to +85°C)
IP66

Response Time

Fuel	Size	Distance Feet (M)	Typical Response Time (Sec.)
n-Heptane	1 ft x 1 ft	210 (64.0)	5.0
Methanol	1 ft x 1 ft	150 (45.7)	7.0
JP5	2 ft x 2 ft	210 (64.0)	4.5

Field of View

Fuel	Horizontal (left)	Horizontal (right)	Vertical (up)	Vertical (down)	Min. Distance Feet (down)	Avg Time
n-Heptane	50°	50°	50°	50°	56.1 (17.1)	3 sec.
Methanol	50°	50°	50°	50°	41.0 (12.5)	3 sec.
JP5	50°	50°	50°	50°	82.0 (25.0)	3 sec.

Electrical Characteristics

Operating Voltage 18 to 32 VDC

Power consumption <2 W, standby
<3 W, during alarm
<7.5 W, with heater on maximum

Analog Outputs HART
4-20mA
Current
Analog signal 2 mA ± 0.1 mA
Fault signal 4 mA ± 0.1 mA
Ready signal 18 mA ± 0.1 mA
Fire signal 8 mA ± 0.1 mA
Test Mode

Digital Outputs RS 485, Modbus RTU, Profibus

Relay Contact Fire Alarm:
- normally open relay
- closed on fire detection
- latching or non-latching
Fault:
- normally closed relay
- open on fault detection

Operating Temperature -40°F to +185°F (-40°C to +85°C)

Extended Operating Temperature (By Request) -75°F to +255°F (-60°C to +125°C)

Storage Temperature -76°F to +185°F (-60°C to +85°C)

Humidity Up to 95 % Relative humidity, non-condensing (withstands up to 100% RH for short periods)

Wiring 14 AWG (2.08 mm2) or 16 AWG (1.31 mm2)
Shielded cable is recommended

SIL Rating SIL 3

Ingress Protection IP66

Viewing Angle

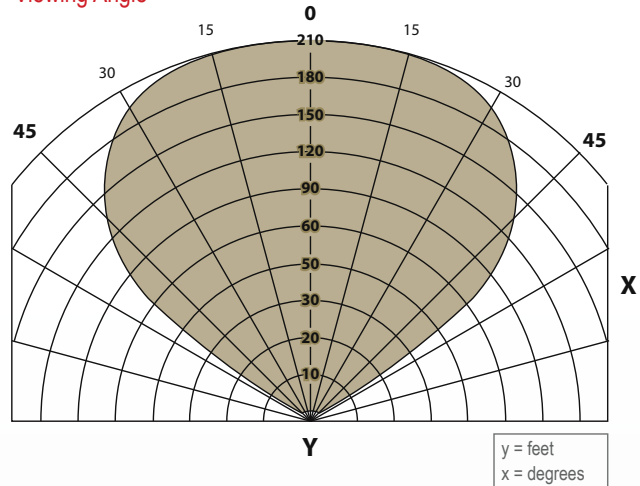

Dimensions

in inches (millimeters)

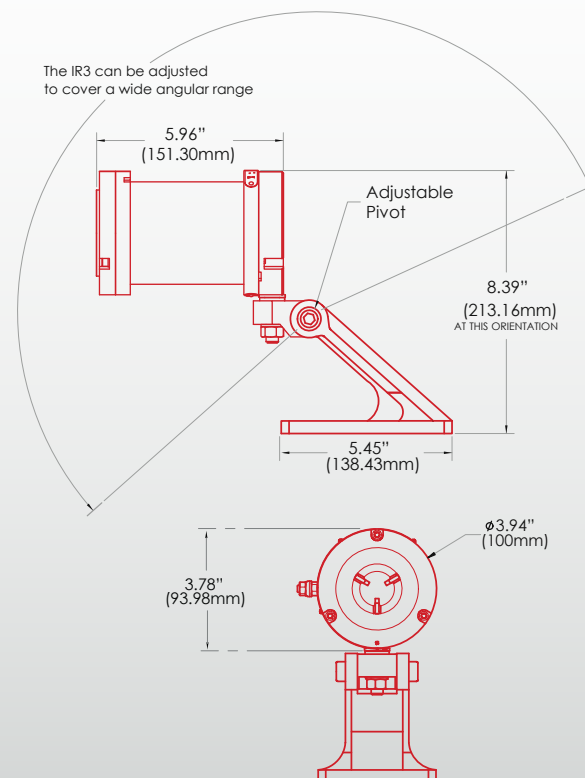

Mechanical Characteristics

Material Aluminum and 316 Stainless Steel

Cable Entry 3/4" NPT

Weight 11 lbs (5.0 kg)

Warranty 5 years

FLAME DETECTOR

IPES IR3

