

NOTE:

- 1. DIMENSIONS ARE FOR REFERENCE ONLY
- 2. DIMENSIONS ARE IN MILLIMETERS. DIMENSIONS IN [] ARE IN INCHES
- 3. M12 SCREWS ARE USED FOR MOUNTING

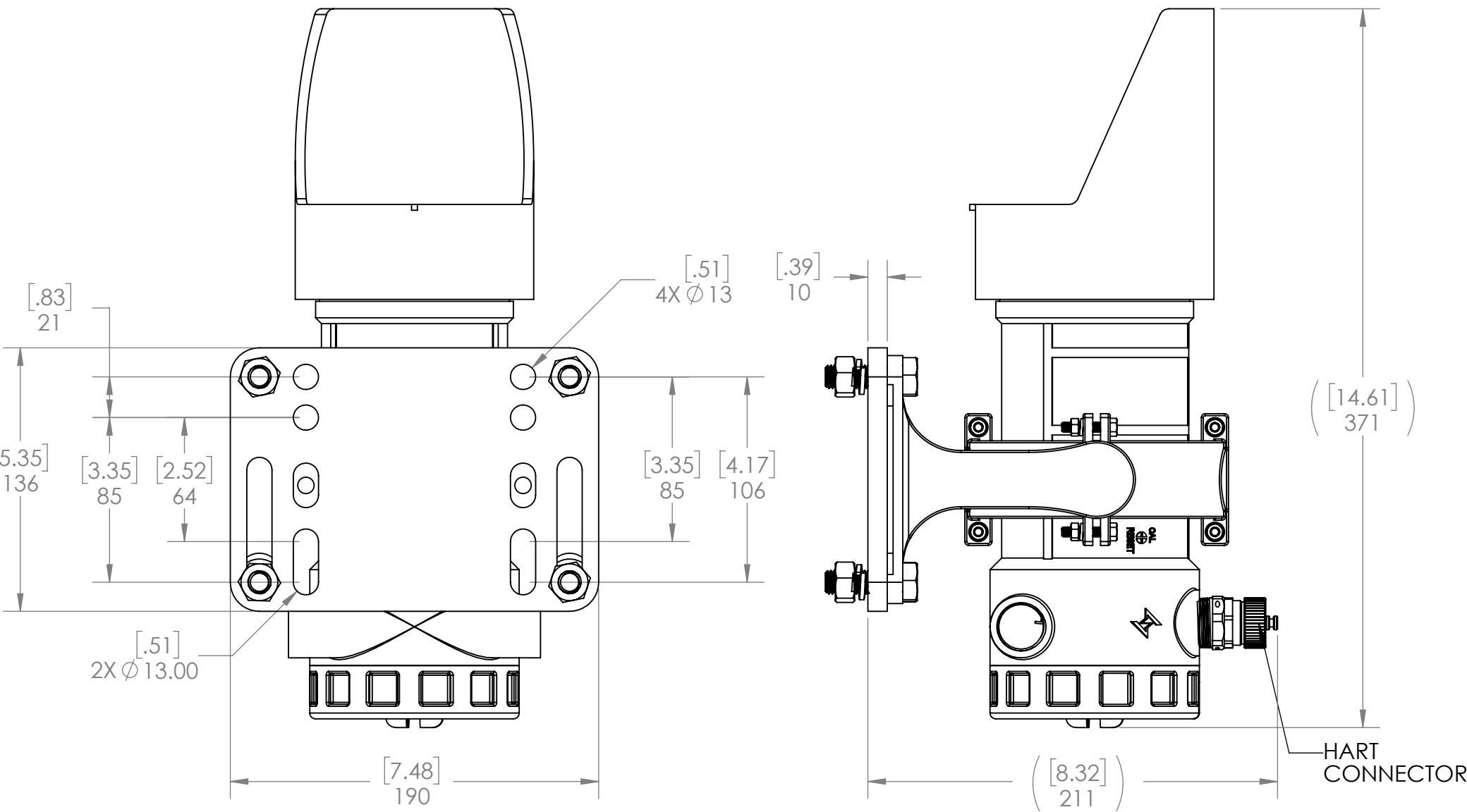

TITLE: TGAES OPEN PATH GAS DETECTOR OVERALL DIMENSIONS
AUTHOR: BW
DRAWN DATE: 04/24/2019
REVISION: 0

